

Assembly Instructions:

1. Place desk work surface on a soft surface to protect from damage – groove-side up. *Fig.1*
2. Position each leg 1" inset on two sides and align with predrilled holes. Fasten leg using the eight 1" Phillips wood screws provided. Repeat for remaining legs. *Fig.2*
3. Carefully flip desk upright. *Fig.3*
4. Move desk to desired location.
5. Place level on work surface and turn glides on each leg by hand until work surface is level. *Fig.3*



Fig.1

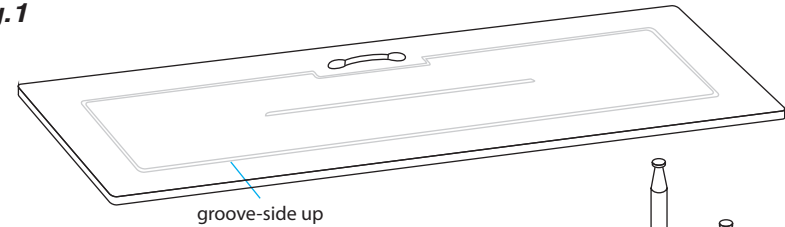

Fig.2

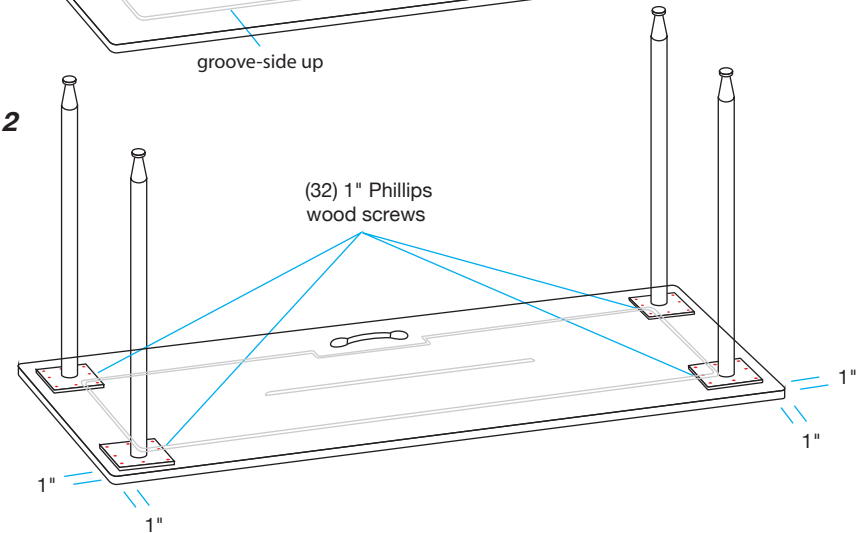
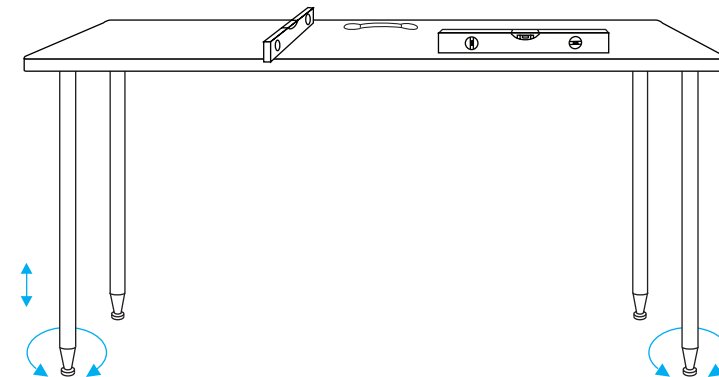

Fig.3



For proper care and cleaning instructions visit <http://go2wfh.com/resources>

Tools Needed:



tape measure



power drill



#2 Phillips bit driver



level

Hardware Included:



(32) 1" Phillips wood screws